



AWA Newsletter

84

January 2013

Affiliated
to the
SARL



Antique
Wireless Association
of Southern Africa

Inside this issue:

CW Net	2
SSB Activity	2
AM	2
Autotransformers	3-5
Presidents Corner	6-7
AWA 10th Celebration	7
Notices	8

AWA Committee:

- * President—Richard ZS6TF
- * Technical Advisor—Rad ZS6RAD
- * Secretary/PRO—Andy ZS6ADY
- * Western Cape—John ZS1WJ

Reflections:

This year sees the 10th Birthday of the AWA in March.

It was in March of 2003 that the first gathering of the AWA took place on 7070 on a Saturday morning.

There were 5 stations on frequency and the inaugural meeting took place where an explanation of how the Collins Collectors group was going to become the Antique Wireless Association of Southern Africa so as to widen its scope and allow a greater membership of people with a common interest in valve technology and the restoration and use of yesterdays radios.

Since then, the AWA have met every Saturday morning at 08:30 on 7070 and have grown to the stage

where we are today.

During this time period we have seen 8 Presidents come and go, each of them departing some new ideas to the running of the AWA and to the activities of the AWA.

Cliff ZS6BOX was voted in as the founding President and was responsible for the first year of running the AWA.

We had Willem ZS6ALL step up to run the net as net controller, which he did so effectively for many years.

We had Allan ZS.. Who stepped in as PRO for the AWA and was responsible for obtaining the ZS0AWA call sign and for many years paid the licence fees out of his own pocket . Allan was also responsible for

arranging the first AWA open day at Rand Airport, where we possibly had the largest turnout that we have ever had at one of our Open Days.

We could possibly mention all of those who have participated in some way to the growth and stability of the AWA, for there certainly have been many of them, but I would need a lot more space.

The majority who have added to the AWA are the members of the AWA who contribute at every net to the maintenance and use of valve radios. It is the membership who keep it alive by their participation. The leadership is simply there to encourage and direct them.

Best 73

DE Andy ZS6ADY

WIKIPEDIA

The earliest radio stations were simply radiotelegraphy systems and did not carry audio. The first claimed audio transmission that could be termed a *broadcast* occurred on Christmas Eve in 1906, and was made by Reginald Fessenden. Whether this broadcast actually took place is disputed. While many early experimenters attempted to create systems similar to radiotelephone devices by which only two parties were meant to communicate, there were others who intended to transmit to larger audiences. Charles Herrold started broadcasting in California in 1909 and was carrying audio by the next year. (Herrold's station eventually became KCBS).

For the next decade, radio tinkerers had to build their own radio receivers. In The Hague, the Netherlands, PCGG started broadcasting on November 6, 1919. In 1916, Frank Conrad, an employee for the Westinghouse Electric Corporation, began broadcasting from his Wilkensburg, Pennsylvania garage with the call letters 8XK. Later, the station was moved to the top of the Westinghouse factory building in East Pittsburgh, Pennsylvania. Westinghouse re-launched the station as KDKA on November 2, 1920, claiming to be "the world's first commercially licensed radio station". The commercial broadcasting designation came from the type of broadcast license; advertisements did not air until years later. The first licensed broadcast in the United States came from KDKA itself: the results of the Harding/Cox Presidential Election. The Montreal station that became CFCF began broadcast programming on May 20, 1920, and the Detroit station that became WWJ began program broadcasts beginning on August 20, 1920, although neither held a license at the time.

Radio Argentina began regularly scheduled transmissions from the Teatro Coliseo in Buenos Aires on August 27, 1920, making its own priority claim. The station got its license on November 19, 1923. The delay was due to the lack of official Argentine licensing procedures before that date. This station continued regular broadcasting of entertainment and cultural fare for several decades.

Radio in education soon followed and colleges across the U.S. began adding radio broadcasting courses to their curricula. Curry College in Milton, Massachusetts introduced one of the first broadcasting majors in 1932 when the college teamed up with WLOE in Boston to have students broadcast programs.

CW Net:

Resolutions. I am not great on them, but I try to make no more than 3 of them so that I can keep an eye on my progress. One of the resolutions that I made for 2012 was to work 100 countries on CW during 2012. I ended up with 118 and am very happy that I achieved that target.

When I think back on my efforts on CW over the years I am so glad that I decided to make CW my hobby.

I was a reluctant starter as I was embarrassed that I could send at 12 wpm but could only read at about 8 wpm and then only, if the CW sent was sent with good spacing. The thing is to get on the air and send at the speed you can read. I used to have a note on my desk saying "Slow Down!" as sometimes I would get excited and start shortening the gaps between letters and hence making my CW difficult to read. One thing that helped me was a CW reader. I would plug my key (and later on my paddle) directly into the reader. I would send the alphabet over and over again whilst looking at the screen to

make sure that the reader was reading my CW correctly. Of course it was reading my CW correctly, but a lot of the time I was not sending correctly!

It helps to have an Elmer. I was lucky in having a few people that were better than me at CW who would meet me around the watering hole of 7.020.

They were always patient with my CW. It was by having those Elmer's to QSO with that gave me the confidence over the years to SLOWLY speed up my sending. (In fact my sending was never the problem, it was the receiving that slowed me down.) Be prepared to be embarrassed if you send faster than you can receive as that other station may come back to you at your sending speed and you find you cannot read his fast CW!

It was only 5 years ago that I decided that CW was what I was going to concentrate on. In the last 4 years I have not used SSB. Without being

conscious of it, I have built up my receiving speed to about 28 wpm. If the other station has a good rhythm then I can read faster, but I like to go no faster than 28wpm. Admittedly a lot of my QSO's are rubber stamp ones these days (well you can't expect to ragchew with someone who knows no English!) but I do get a few nice ragchews and it gives me a good feeling that I am sending easy to read CW.

So Andy and other potential CW operators, just keep slowly plugging away and you will get the satisfaction of CW - no matter what speed you use. I can't remember how many people told me but, what you need is practice and then more practice. CW improvement will not come with a once a week QSO, it needs about 30 mins a night to get the old grey matter in the head in tune with your fingers.

Stay healthy in 2013 and keep practicing and find an Elmer that will keep you on the air.

73 de Ian—ZL2AIM

SSB activity:

Call in's on the SSB net have really started to reach a high these days. The band seems to be in fairly good shape and more often than not all stations are coming in a good Q5 readability.

Of course we think this may be as a result of the subjects that have been chosen for all to impart some knowledge on in discussion format during the net. It certainly has made a difference to the time slot of the net.

Normally everybody signing in would get at least two turns in the one hour slot we have been using previously, but these days everybody only gets one turn in a one and a half hour slot.

This is of course, thanks to all those who contribute something directly or indirectly to the net.

We don't expect everybody to have something to say, but most times the topics are of great interest to all who join the net. This makes it most interesting and the time really flies.

If you have not been on frequency in a while, you will be greatly surprised if you join in anytime soon.

It seems there is still a great deal of refurbishment going on with the members of AWA and judging by a lot of comments on

the nets, this is really encouraging to hear.

Lets face it, the old rigs are still a great way to play around and test your skills in amateur



Drake T4X

AM:

The AM net has also started to gain popularity these days with 7 to 8 stations calling in on a Saturday morning.

Not everyone tests Music on the net, but it is still so good to hear the number of people that are gaining an interest in operating on AM.

Still the most popular rig for operating is the Yaesu FT101 series and they certainly do hold up well in the early morning hours. Then comes the Hallicrafters, the Collins and the other rigs that have made their names in amateur radio. Some good combinations of transmitters and receivers.

The net starts at around 05:00 because conditions to div 5 tend to fade quite early so it

is a case of the early bird catching the band. As the winter months draw closer and sunrise moves to a later spot, the net times will move out with it. But don't expect this to be happening any time too soon.

The punishment of dragging your body out of bed to go and play radio at such an early spot is still quite reasonable, its in the winter months that one starts to regret being so keen.

Wednesday evenings are also gaining in popularity as the constant summer storms start to fade and we have had 2 evenings already when band conditions on 80m have been fairly good.

S9+, Q5 reports are quite easy to maintain as

the band opens up later in the evening.

From around 19:00, conditions are already pretty good, but one has to look out for the odd storm that is still floating around.



Lafayette Voyager

AUTOTRANSFORMERS.

After following an extremely interesting thread on autotransformers, I searched around for information on this subject as I do believe it is of great interest to collectors and users of valve equipment.

An **autotransformer** (sometimes called *auto step down transformer*) is an electrical transformer with only one winding. The "auto" (Greek for "self") prefix refers to the single coil acting on itself and not to any kind of automatic mechanism. In an autotransformer portions of the same winding act as both the primary and secondary. The winding has at least three taps where electrical connections are made. Autotransformers have the advantages of often being smaller, lighter, and cheaper than typical dual-winding transformers, but autotransformers have the disadvantage of not providing electrical isolation.

Autotransformers are often used to step up or step down voltages in the 110-117-120 volt range and voltages in the 220-230-240 volt range—for example, providing 110 or 120V (with taps) from 230V input, allowing equipment designed for 100 or 120 volts to be used with a 230 volt supply (as in using US electrical equipment in with higher European voltages).

An autotransformer has a single winding with two end terminals, and one or more terminals at intermediate tap points. The primary voltage is applied across two of the terminals, and the secondary voltage taken from two terminals, almost always having one terminal in common with the primary voltage. The primary and secondary circuits therefore have a number of windings turns in common.^[2] Since the volts-per-turn is the same in both windings, each develops a voltage in proportion to its number of turns. In an autotransformer part of the current flows directly from the input to the output, and only part is transferred inductively, allowing a smaller, lighter, cheaper core to be used as well as requiring only a single winding.

Operation:

One end of the winding is usually connected in common to both the voltage source and the electrical load. The other end of the source

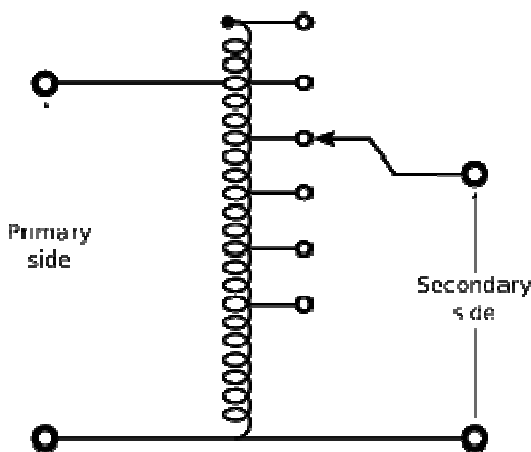

and load are connected to taps along the winding. Different taps on the winding correspond to different voltages, measured from the common end. In a step-down transformer the source is usually connected across the entire winding while the load is connected by a tap across only a portion of the winding. In a step-up transformer, conversely, the load is attached across the full winding while the source is connected to a tap across a portion of the winding.

As in a two-winding transformer, the ratio of secondary to primary voltages is equal to the ratio of the number of turns of the winding they connect to. For example, connecting the load between the middle and bottom of the autotransformer will reduce the voltage by 50%. Depending on the application, that portion of the winding used solely in the higher-voltage (lower current) portion may be wound with wire of a smaller gauge, though the entire winding is directly connected.

Limitations:

An autotransformer does not provide electrical isolation between its windings as an ordinary transformer does; if the neutral side of the input is not at ground voltage, the neutral side of the output will not be either. A failure of the insulation of the windings of an autotransformer can result in full input voltage applied to the output. Also, a break in the part of the winding that is used as both primary and secondary will result in the transformer acting as an inductor in series with the load (which under light load conditions may result in near full input voltage being applied to the output). These are important safety considerations when deciding to use an autotransformer in a given application.

Because it requires both fewer windings and a smaller core, an autotransformer for power applications is typically lighter and less costly than a two-winding transformer, up to a voltage ratio of about 3:1; beyond that range, a two-winding transformer is

usually more economical.

In three phase power transmission applications, autotransformers have the limitations of not suppressing harmonic currents and as acting as another source of ground fault currents. A large three-phase autotransformer may have a "buried" delta winding, not connected to the outside of the tank, to absorb some harmonic currents.

In practice, losses mean that both standard transformers and autotransformers are not perfectly reversible; one designed for stepping down a voltage will deliver slightly less voltage than required used to step up. The difference is usually slight enough to allow reversal where the actual voltage level is not critical.

Like multiple-winding transformers, autotransformers operate on time-varying magnetic fields and so will not function with DC.

Applications:

Power distribution - Autotransformers are frequently used in power applications to interconnect systems operating at different voltage classes, for example 138 kV to 66 kV for transmission. Another application is in industry to adapt machinery built (for example) for 480 V supplies to operate on a 600 V supply. They are also often used for providing conversions between the two common domestic mains voltage bands in the world (100-130 and 200-250). The links between the UK 400 kV and 275 kV 'Super Grid' networks are normally three phase autotransformers with taps at the common neutral end.

On long rural power distribution lines, special autotransformers with automatic tap-changing equipment are inserted as voltage regulators, so that customers at the far end of the line receive the same average voltage as those closer to the source. The variable ratio of the autotransformer compensates for the voltage drop along the line.

A special form of autotransformer called a *zig zag* is used to provide grounding (earthing) on three-phase systems that otherwise have no connection to ground (earth). A zig-zag transformer provides a path for current that is common to all three phases (so-called *zero sequence* current).

In audio applications, tapped autotransformers are used to adapt speakers to constant-voltage audio distribution systems, and for impedance matching such as between a low-impedance microphone and a high-impedance amplifier input.

In comparison, a normal induction transformer is a static electrical device that transfers energy by inductive coupling between its winding circuits. A varying current in the *primary* winding creates a varying magnetic flux in the transformer's core and thus a varying magnetic flux through the *secondary* winding. This varying magnetic flux induces a varying electromotive force (EMF), or "voltage", in the secondary winding.

Transformers range in size from a thumbnail-sized coupling transformer hidden inside a stage microphone to huge units weighing hundreds of tons used in power plant substations or to interconnect portions of the power grid. All operate on the same basic principles, although the range of designs is wide. While new technologies have eliminated the need for transformers in some electronic circuits, transformers are still found in many electronic devices. Transformers are essential for high-voltage electric power transmission, which makes long-distance transmission economically practical.

The principle behind the operation of a transformer, electromagnetic induction, was discovered independently by Michael Faraday and Joseph Henry in 1831. However, Faraday was the first to publish the results of his experiments and thus receive credit for the discovery. The relationship between electromotive force (EMF) or "voltage" and magnetic flux was formalized in an equation now referred to as "Faraday's law of induction".

Faraday performed the first experiments on induction between coils of wire, including winding a pair of coils around an iron ring, thus creating the first toroidal closed-core transformer. However he only applied individual pulses of current to his transformer, and never discovered the relation between the turns ratio and EMF in the windings.

The first type of transformer to see wide use was the induction coil, invented by Rev. Nicholas Callan of Maynooth College, Ireland in 1836. He was one of the first researchers to realize that the more turns the secondary winding has in relation to the primary winding, the larger is the increase in EMF. Induction coils evolved from scientists' and inventors' efforts to get higher voltages from batteries. Since batteries produce direct current (DC) rather than alternating current (AC), induction coils relied upon vibrating electrical contacts that regularly interrupted the current in the primary to create the flux changes necessary for induction. Between the 1830s and the 1870s, efforts to build better induction coils, mostly by trial and error, slowly revealed the basic principles of transformers.

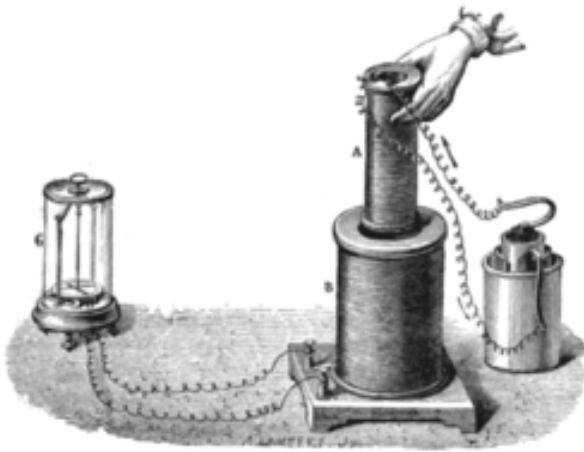

Faraday's experiment with induction between coils of wire



Faraday's ring transformer

The transformer is based on two principles: first, that an electric current can produce a magnetic field (electromagnetism) and second that a changing magnetic field within a coil of wire induces a voltage across the ends of the coil (electromagnetic induction). Changing the current in the primary coil changes the magnetic flux that is developed. The changing magnetic flux induces a voltage in the secondary coil.

An ideal transformer is shown in the figure below. Current passing through the primary coil creates a magnetic field. The primary and secondary coils are wrapped around a core of very high magnetic permeability, such as iron, so that most of the magnetic flux passes through both the primary and secondary coils. If a load is connected to the secondary winding, the load current and voltage will be in the directions indicated, given the primary current and voltage in the directions indicated (each will be alternating current in practice).

Induction law

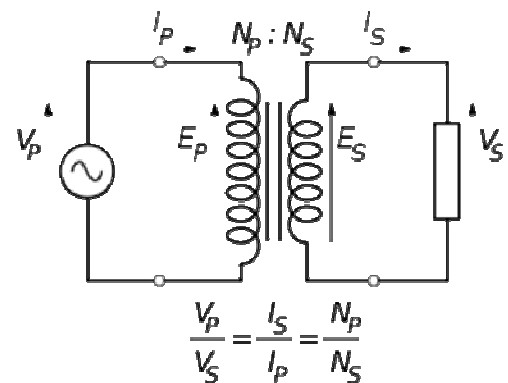
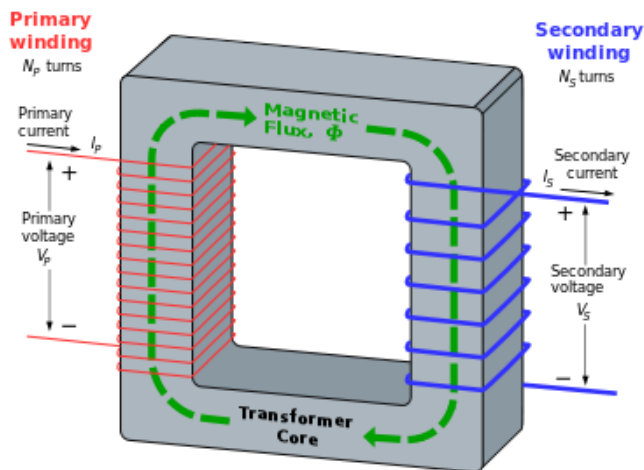

The ideal transformer as a circuit element

An ideal voltage stepdown transformer.
The secondary current arises from the action of the secondary EMF on the (not shown) load impedance.

(Information gleaned from Wikipedia. For more on this subject, search the Wikipedia files for formula's on transformers)

PRESIDENT'S CORNER

By Richard ZS6TF

The romance of radio.

One of the downsides of the digital era in which we live is that everything gets reduced to numbers. I often hear amateurs say "I'm on the 830 today" and a casual listener could be forgiven for thinking they are sitting on the Gautrain. Fast rewind to the nineteen twenties and thirties and you will discover a wealth of "wireless speak" belonging to an ancient analogue world of mystery and endeavour where valves ruled the airwaves. The Superheterodyne was invented by Edwin Armstrong in 1918 and manufacturers went to great lengths to coin exclusive names for their alternative designs such as Fremodyne, Autodyne, Selectrodyne, Infradyne, Novodyne, Tetradyne, and Homodyne. These names were mostly marketing hype but one good effort was the Neutrodyne invented by Louis Hazeltine in the early 20's, a receiver in which a portion of the signal is capacitively fed back to a previous stage to neutralise the high inter-electrode capacitances of the valves of the era thus curing RF instability. Armstrong went on to invent FM in 1933, most receivers today are superhets, and FM still predominates for local broadcasting although the digital threat is upon us.

To make all this magic work, oscillators were the Holy Grail of the time. Armstrong invented his in 1913, and although widely used in domestic radios due to its simplicity, its stability was poor. Ralph Hartley developed his design in 1915 using a tapped "coil and single condenser in the tank circuit", followed by Edwin H Colpitts who came up with the oscillator with his name in 1918, which is the electrical dual of the Hartley using a "condenser divider and a single coil". In the heyday of AM radio these were sufficient until the post war years when James Clapp came along with his design in 1948 (Homodynes beware!)

One of the more unique and collectable early National receivers is the National SW-5, an AC mains powered short wave unit which was produced in 1930 and labelled by National in their marketing literature as the "Thrill Box".



In those days frequency was given in cycles, using kilo, and mega prefixes to control the noughts, but stations were often referred to by their wavelength in metres.

The picture above appeared in QST in September 1938 and depicts an all 6L6 transmitter built up from Utah amateur "add-a-kit" parts, a Hammarlund super-Pro SP10 receiver, and the obligatory Astatic D104.

To tune up your TX in those days you would need to connect your artificial aerial to the aerial coupler, and plug in the appropriate band coils. Filaments and bias on first and then the plate supply. After setting the approximate frequency, a quick dip of the Master oscillator plate current, followed by a frequency check on the heterodyne wavemeter or receiver for frequency fine adjustment and MO valve loading to rated current. Next the transmitter would be keyed to dip the final plate current with the plate tank condenser. This would be followed by increasing the grid current by ad-



vancing the final grid tank tuning condenser until the final plate current was at the correct level (consult the ARRL handbook tube data if in doubt). A quick check that the grid current is safe and a tweak on the final plate dip and the transmitter is now tuned to resonance on the MO frequency, ready for CW transmission. For AM the modulator was brought in and the audio level advanced until 70% was registered on the modulation meter. The transmitter was usually keyed by the morse key for voice transmission and the relay muted the receiver by removing the HT. Time now to connect the aerial and the aerial coupler is tuned for maximum aerial RF amps with a quick trim on the final tuning in between, and then CQ may be called. All of this magic took place without a dummy load, a VFO and an antenna, you understand. 73 and enjoy your antique wireesses in 2013.

AWA 10th Birthday.

For those of you who have been with us from the beginning, you may just remember that it was in March 2003 that the first meeting on air of the AWA of Southern Africa was took place.

Now it is 10 years later and we are celebrating 10 years of being on the air and many various activities that take place on air. In celebration of this, we have designed a special celebratory QSL card.

In order for you to get this celebratory QSL card, you need to contact ZS0AWA during one of the QSO parties, or activity days that take place during the year. That would be the CW activity day on the 3rd and 4th of February. The AWA QSO party on AM and SSB on the 11th and 12th May and the QSO party on the 12th and 13th October.

Should you have a QSO with ZS0AWA on any of these dates, send us a QSL with a SASE and we will send you the QSL Card.

*** ZS0AWA - 10**





THE OFFICIAL CALL SIGN
OF THE SOUTHERN
AFRICAN ANTIQUE
WIRELESS ASSOCIATION

10TH ANNIVERSARY
2003 - 2013

To Radio	Date	UTC	MHz	Mode	RST

Many thanks for our QSO, PSE / TNX QSL! **73 de ZS0AWA**

2003 CLIFF ZS6BOX
2004 BUSHY ZS6M(SK)

2005 ROD ZS5RK
2006 ANDY ZS6ADY

2007 GARY ZS5NK
2008/9 RAD ZS6RAD

2010/11 DON ZS5DR
2012/13 RICHARD ZS6TF

CONTACT US:

P.O. Box 12320
Benoryn
1504

Fax: 27 86 620 3291
Mobile: 082 448 4368
Email: andyzs6ady@vodamail.co.za

Get your backdated issues at
[http://groups.yahoo.com/
group/AWA_SA/](http://groups.yahoo.com/group/AWA_SA/)

**Antique Wireless Association
of Southern Africa**

Mission Statement

Our aim is to facilitate, generate and maintain an interest in the location, acquisition, repair and use of yester-days radio's and associated equipment. To encourage all like minded amateurs to do the same thus ensuring the maintenance and preservation of our amateur heritage.

Membership of this group is free and by association.

Notices:**NET TIMES AND FREQUENCIES:**

The following are times and frequencies for the AWA nets:

AM Net—Wednesday evenings from around 19:00, when band conditions allow.
Saturday mornings from around 05:00. Frequency—3615.

SSB Net—Western Cape net Saturday morning from 07:30. Frequency 7070
National net Saturday mornings from 08:30. Frequency —7070

CW Net—Saturday afternoon from 14:00. Frequency—7020.

(Times given are CAT or SAST)
